

INDICE	INDEX	INHALTSVERZEICHNIS	
1.0 Caratteristiche	<i>Characteristics</i>	Merkmale	2
1.1 Designazione	<i>Designation</i>	Bezeichnung	3
1.2 Selezione	<i>Selection</i>	Getriebeauswahl	3
1.3 Carichi radiali e assiali su albero lento	<i>Radial and axial load on output shaft</i>	Radial-und Axiallasten an der Ausgangswelle	4
1.4 Lubrificazione	<i>Lubrication</i>	Schmierung	4
1.5 Dati tecnici	<i>Technical data</i>	Technische Daten	5
1.6 Dimensioni	<i>Dimensions</i>	Abmessungen	6-15
1.7 Istruzioni per il montaggio del motore	<i>Instructions for assembly of motor</i>	Anleitung für Motormontage	16



1.0 Caratteristiche

La serie di riduttori epicicloidali EP è il risultato di un ottimo rapporto tra economicità del prezzo e garanzia di precisione delle caratteristiche di funzionamento.

I nostri riduttori sono stati realizzati per un utilizzo prevalente sulle seguenti applicazioni:

- Macchine utensili
- Macchine per la lavorazione del legno
- Linee transfer
- Macchine da stampa
- Macchine automatiche per confezionamento ed imballaggio
- Automazioni
- Manipolatori
- Macchine serigrafiche
- Guide lineari

La gamma dei riduttori è costituita da 5 grandezze (55, 75, 90, 120 e 155), a 1 e 2 stadi di riduzione, ognuna con due tipi di alberi uscita (tipo A e tipo T) e flange uscita di tipo A, T e Q.

Corpo: costruito in acciaio, garantisce robustezza e una elevata affidabilità nel tempo.

Flange: le flange in entrata ed in uscita sono costruite in alluminio e sono disponibili in molteplici varianti costruttive.

Alberi: sono costruiti in acciaio legato bonificato.

Ingranaggi: in acciaio legato da cementazione e tempra, con dentature rettificata.

Cuscinetti: di elevata qualità opportunamente dimensionati per garantire elevate durate e silenziosità di funzionamento.

1.0 Characteristics

The planetary gearbox EP series is the result of the outstanding ratio competitive price / precision guaranteed with regard to operating features.

Our gearboxes are manufactured for prevailing utilization in the following applications:

- *Machine tools*
- *Machines for woodworking*
- *Transfer machines*
- *Printing machines*
- *Automatic machines for packaging*
- *Automation*
- *Mechanical hands*
- *Silk-screen process machines*
- *Linear guides*

The EP series is available in 5 sizes (55, 75, 90, 120 and 155), with 1 or 2 reduction stages, with two types of output shaft (A and T) and three types of output flange (A, T and Q).

Housing: *made of special nitrided steel to assure strength, high reliability and long life.*

Flanges: *input and output flanges made of aluminium and available in several versions.*

Shafts: *made of hardened and tempered alloy steel.*

Gears: *made of casehardened and tempered alloy steel, with ground toothing.*

Bearings: *high quality and suitably sized to assure long life and noiseless working.*

1.0 Merkmale

Die EP Serie von Planetengetrieben ist das Ergebnis des hervorragenden Verhältnis guten Preis / garantierte Präzision der Betriebseigenschaften. Unsere Getriebe sind für überwiegende Verwendung in der folgenden Applikationen hergestellt:

- Werkzeugmaschinen
- Holzbearbeitungsmaschinen
- Transfermaschinen
- Druckmaschinen
- Automatische Verpackungsmaschinen
- Automation
- Manipulatoren
- Siebdruckmaschinen
- Linearführungen

Die EP Serie ist in 5 Größen (55, 75, 90, 120 und 155) mit 1 oder 2 Untersetzungsstufen, mit zwei Typen von Abtriebswellen (A und T) und drei Typen von Abtriebsflanschen (A, T und Q) verfügbar.

Gehäuse: aus Spezial-Nitrierstahl. Garantiert Robustheit und dauerhaft hohe Zuverlässigkeit.

Ein- u. Ausgangsflansche: aus Aluminium, in zahlreichen Varianten lieferbar.

Wellen: aus vergütetem Legierungsstahl.

Zahnräder: aus Einsatzstahl mit geschliffenen Zahnflanken.

Lager: sind hochwertig und zweckmäßig bemessen, um eine lange Lebensdauer und einen geräuscharmen Lauf zu garantieren.

1.1 Designazione

1.1 Designation

1.1 Bezeichnung

Riduttore epicicloidale Planetary gearbox Planetengetriebe	Grandezza Size Größe	Numero di stadi Steps Untersetzungsstufen	Coassiale Coaxial Koaxial	Rapporto di riduzione Ratio Untersetzungsverhältnis	Albero uscita Output shaft Durchmesser Abtriebswelle	Flangia uscita Output flange Ausgangsflansch	Albero entrata Input shaft Durchmesser Eingangswelle	Flangia in entrata Input flange Eingangsflansch
EP	55	2	C	100	A	A	AE..	P..
	55 75 90 120 155	1 2	C	3 - 100	A T	A T Q	Vedi tabella See tables Siehe Tab.	Vedi tabella See tables Siehe Tab.

1.2 Selezione

La selezione dei riduttori epicicloidali EP deve essere effettuata valutando se il servizio è intermittente o continuo verificando le seguenti relazioni.

1) Per servizio intermittente:

$$T_m \cdot i \cdot R_D \cdot fc \leq T_{2N}$$

2) Per servizio continuo:

$$T_m \cdot i \cdot R_D \cdot fc / 0.65 \leq T_{2N}$$

dove:

T_m = coppia nominale del motore (Nm)

i = rapporto di trasmissione del riduttore

R_D = rendimento dinamico

fc = fattore ciclo (vedi tabella)

1.2 Selection

The selection of planetary gearboxes EP series has to be made after the checking of service factor. For intermittent or continuous duty it is necessary to apply the following formulas:

1) Intermittent duty:

$$T_m \cdot i \cdot R_D \cdot fc \leq T_{2N}$$

2) Continuous duty:

$$T_m \cdot i \cdot R_D \cdot fc / 0.65 \leq T_{2N}$$

where:

T_m = nominal torque of motor (Nm)

i = transmission ratio of gearbox

R_D = dynamic efficiency

fc = cycle factor (see table)

1.2 Getriebeauswahl

Bei der Auswahl der Planetengetriebe EP muß berücksichtigt werden, ob diese im Aussetzbetrieb oder im Dauerbetrieb eingesetzt werden:

1) Aussetzbetrieb:

$$T_m \cdot i \cdot R_D \cdot fc \leq T_{2N}$$

2) Dauerbetrieb:

$$T_m \cdot i \cdot R_D \cdot fc / 0.65 \leq T_{2N}$$

wobei:

T_m = Nennmoment des Motors (Nm)

i = Untersetzungsverhältnis

R_D = Dynamischer Wirkungsgrad

fc = Zyklusfaktor (s. Tabelle)

Cicli/ora - cycle/h - Zyklen/h	1000	1000/2000	2000/3000
fc	1	1.2/1.5	1.5/2

Nelle applicazioni dove sono previsti cicli di funzionamento caratterizzati da frequenti accelerazioni è necessario verificare che la coppia massima di accelerazione sia uguale o inferiore al valore di T_{2A} indicato nelle tabelle.

For application with operation cycles based on frequent accelerations it is necessary to verify that max acceleration torque is equal or inferior to the T_{2A} value shown in the tables.

Bei Anwendungen mit häufigen Beschleunigungen muß sichergestellt werden, daß das maximale Beschleunigungsmoment nicht höher ist als die in der Tabelle aufgeführten Werte T_{2A} .

1.3 Gioco angolare (max)

Gioco massimo [arcmin] misurato sull'albero uscita, con albero entrata bloccato applicando una coppia pari al 2% della coppia nominale.

1.3 Backlash (max)

Max. backlash measured on output shaft by torque equals to 2% of the nominal torque value with input shaft blocked.

1.3 Spiel (max)

Maximales Spiel [arcmin], gemessen an der Abtriebswelle bei blockierter Eingangswelle mit 2% des Nennmoments.

1.3 Carichi radiali e assiali su albero lento

Nella tabella delle prestazioni sono indicati i valori, espressi in N, dei carichi assiali e radiali ammissibili alle diverse velocità per una durata dei cuscinetti di 20.000 ore. Il carico radiale F_{R2} si considera applicato ad una distanza dalla battuta pari alla metà della lunghezza dell'albero lento. Per distanze y diverse, è possibile calcolare il nuovo carico massimo ammissibile F_{R2Y} utilizzando formula e coefficienti indicati nella tabella.

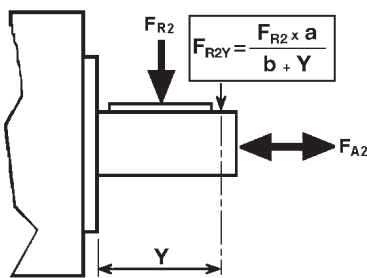

1.3 Radial and axial load on output shaft

The table of performances shows admissible axial and radial load values expressed in N for different speeds and for a bearing life of 20.000 hours. Radial load F_{R2} calculations have been based on loads applied to the center line of the output shaft extension. For different y distance it is possible to calculate the new maximum admissible load by using formula and coefficient shown in the table.

1.3 Radial-und Axiallasten an der Ausgangswelle

Die Leistungstabelle enthält die in N ausgedrückten Werte der Axial- und Radiallasten für verschiedene Umdrehungszahlen. Diesen Werten liegt eine Lebensdauer der Lager von 20.000 Stunden zugrunde. Die Radiallast F_{R2} greift hierbei auf der Mitte der Abtriebswelle an. Greift die Radiallast an einem anderen Punkt der Abtriebswelle an, so kann man die zulässige Radiallast mit der folgenden Formel sowie den dazugehörigen Koeffizienten berechnen:

	EP 55	EP 75	EP 90	EP 120	EP 155
a	27	46	56	77	95
b	18	32	39	52	64

1.4 Lubrificazione

I riduttori EP sono forniti completi di lubrificante a vita pertanto non necessitano di manutenzione. In fase di ordine specificare la posizione di montaggio.

1.4 Lubrication

EP gearboxes are supplied filled with long-life lubricant and do not require any maintenance. When ordering it is important to specify the exact mounting position.

1.4 Schmierung

Die Planetengetriebe EP werden inklusive Dauerschmierung geliefert und sind wartungsfrei. Bei der Bestellung bitte die Einbauposition angeben.

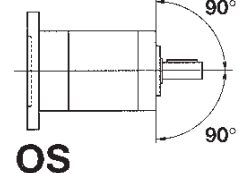
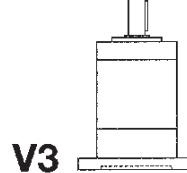
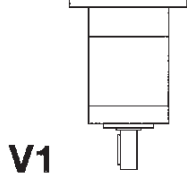
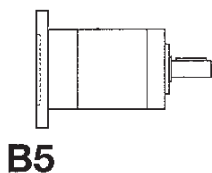

Simbologia e unità di misura

Symbols and unit of measure

Abkürzungen und Maßeinheiten

i	Rapporto di riduzione nominale	Nominal ratio	Nenn-Untersetzungsverhältnis
$n_{1 \text{ nom}}$	Velocità nominale in entrata [min^{-1}]	Nominal input speed [min^{-1}]	Nenn-Eingangsdrehzahl [min^{-1}]
$n_{1 \text{ max}}$	Velocità massima in entrata [min^{-1}]	Maximum input speed [min^{-1}]	Maximale Eingangsdrehzahl [min^{-1}]
T_{2N}	Coppia nominale intermittente in uscita [Nm]	Intermittent output torque [Nm]	Nenn-Abtriebsmoment (im Aussetzbetrieb) [Nm]
T_{2A}	Coppia massima di accelerazione in uscita [Nm]	Maximum acceleration output torque [Nm]	Maximales Beschleunigungsmoment [Nm]
T_{2S}	Coppia massima di emergenza in uscita [Nm]	Maximum emergency output torque [Nm]	Maximale Überlast [Nm]
L_{pA}	Livello di rumorosità dB(A) a 3000 min^{-1}	Noise level dB(A) at 3000 min^{-1}	Geräuschpegel dB(A) bei 3000 min^{-1}
Rd	Rendimento dinamico	Dynamic efficiency	Dynamischer Wirkungsgrad
L_h	Durata cuscinetti [h]	Bearing life [h]	Lebensdauer der Lager [h]
F_{R2}	Carico radiale nominale in uscita [N] a 100 min^{-1}	Output radial load [N] at 100 min^{-1}	Nenn-Radiallast an der Abtriebswelle bei 100 min^{-1}
F_{A2}	Carico assiale in uscita [N] a 100 min^{-1}	Output axial load [N] at 100 min^{-1}	Axiallast an der Abtriebswelle bei 100 min^{-1}
R_t	Rigidità torsionale [Nm / arcmin]	Torsional rigidity [Nm / arcmin]	Drehfestigkeit [Nm / arcmin]
J_{max}	Gioco angolare standard [arcmin]	Standard backlash [arcmin]	Standard Spiel [arcmin]
J_{min}	Momento d'inerzia minimo [$\text{kg}\cdot\text{cm}^2$]	Min. moment of inertia [$\text{kg}\cdot\text{cm}^2$]	Traegsheitsmoment min. [$\text{kg}\cdot\text{cm}^2$]
J_{max}	Momento d'inerzia massimo [$\text{kg}\cdot\text{cm}^2$]	Max. moment of inertia [$\text{kg}\cdot\text{cm}^2$]	Traegsheitsmoment max. [$\text{kg}\cdot\text{cm}^2$]

1.5 Dati tecnici

1.5 Technical data

1.5 Technische Daten

EP 55																			Stadi Steps Stufenzahl		
Stadi Steps Stufenzahl	1					2												kg	1	2	
i	3	4	5	7	10	9	12	15	16	20	25	28	35	40	50	70	100		0.8	1.8	
T _{2N}	12	14	16	12	10	14	16	16	16	16	16	16	16	16	16	14	12	n _{1nom}	4000		
T _{2A}	22	24	24	22	20	24	28	28	28	28	28	28	28	28	28	24	22	n _{1max}	5000		
T _{2S}	44	48	48	44	40	48	56	56	56	56	56	56	56	56	56	48	44	LpA	< 70		
J _{min}	0.0736	0.0626	0.0587	0.0553	0.0536	0.0734	0.0722	0.0718	0.0620	0.0617	0.0580	0.0552	0.0551	0.0536	0.0536	0.0535	0.0535	Lh	20000		
J _{max}	0.0909	0.0799	0.0759	0.0726	0.0709	0.0906	0.0894	0.0889	0.0791	0.0789	0.0751	0.0723	0.0722	0.0707	0.0707	0.0707	0.0706	F _{R2}	300		
Rt	1.0					0.9												0.9		F _{A2}	450
Rd	0.96					0.93												max	15'	20'	

Pag. Page Seite
6

EP 75																			Stadi Steps Stufenzahl		
Stadi Steps Stufenzahl	1					2												kg	1	2	
i	3	4	5	7	10	9	12	15	16	20	25	28	35	40	50	70	100		1.4	2.0	
T _{2N}	22	28	32	28	20	26	32	36	36	36	36	36	36	36	36	30	22	n _{1nom}	4000		
T _{2A}	40	45	50	45	40	50	60	60	60	60	60	60	60	60	60	50	45	n _{1max}	5000		
T _{2S}	80	90	100	90	80	100	120	120	120	120	120	120	120	120	120	100	90	LpA	< 70		
J _{min}	0.1707	0.1163	0.1063	0.0927	0.0860	0.1597	0.1549	0.1538	0.1159	0.1153	0.1017	0.0927	0.0925	0.0860	0.0859	0.0857	0.0857	Lh	20000		
J _{max}	0.2166	0.1622	0.1522	0.1386	0.1319	0.2056	0.2008	0.1997	0.1618	0.1612	0.1476	0.1386	0.1384	0.1319	0.1318	0.1316	0.1316	F _{R2}	1800		
Rt	3.5					3.0												3.0		F _{A2}	1400
Rd	0.96					0.93												max	15'	20'	

Pag. Page Seite
8

EP 90																			Stadi Steps Stufenzahl		
Stadi Steps Stufenzahl	1					2												kg	1	2	
i	3	4	5	7	10	9	12	15	16	20	25	28	35	40	50	70	100		2.8	3.7	
T _{2N}	50	55	60	55	50	65	70	75	75	75	75	75	75	75	75	65	55	n _{1nom}	4000		
T _{2A}	80	90	100	90	80	100	110	120	120	120	120	120	120	120	120	100	90	n _{1max}	5000		
T _{2S}	160	180	200	180	160	200	220	240	240	240	240	240	240	240	240	200	180	LpA	< 70		
J _{min}	0.5159	0.3371	0.2742	0.2247	0.2008	0.5193	0.4995	0.4925	0.3272	0.3233	0.2651	0.2215	0.2202	0.1992	0.1985	0.1980	0.1978	Lh	20000		
J _{max}	0.7271	0.5483	0.4854	0.4359	0.4120	0.7305	0.7305	0.7036	0.5384	0.5345	0.4763	0.4326	0.4314	0.4103	0.4097	0.4092	0.4090	F _{R2}	2600		
Rt	9.0					7.5												7.5		F _{A2}	2000
Rd	0.96					0.93												max	15'	20'	

Pag. Page Seite
10

EP 120																			Stadi Steps Stufenzahl				
Stadi Steps Stufenzahl	1					2												kg	1	2			
i	3	4	5	7	10	9	12	15	16	20	25	28	35	40	50	70	100		5.9	8.6			
T _{2N}	120	150	180	150	100	150	180	220	220	220	220	220	220	220	220	170	110	n _{1nom}	3000				
T _{2A}	190	240	290	220	180	240	290	350	350	350	350	350	350	350	350	270	200	n _{1max}	4000				
T _{2S}	400	500	600	460	380	500	600	700	700	700	700	700	700	700	700	540	400	LpA	< 70				
J _{min}	2.0027	1.1339	0.8557	0.6244	0.5047	1.9802	1.8962	1.8552	1.0736	1.0505	0.8023	0.6048	0.5977	0.4951	0.4918	0.4895	0.4883	Lh	20000				
J _{max}	4.1528	3.2840	3.0058	2.7745	2.6548	3.1885	3.1045	3.0636	2.2819	2.2589	2.0106	1.8132	1.8061	1.7035	1.7002	1.6979	1.6967	F _{R2}	4500				
Rt	32					28	32	30												28		F _{A2}	4000
Rd	0.96					0.93												max	15'	20'			

Pag. Page Seite
12

EP 155																			Stadi Steps Stufenzahl			
Stadi Steps Stufenzahl	1					2												kg	1	2		
i	3	4	5	7	10	9	12	15	16	20	25	28	35	40	50	70	100		10.9	15.7		
T _{2N}	240	320	380	300	220	320	400	500	500	500	500	500	500	500	500	350	250	n _{1nom}	3000			
T _{2A}	420	540	600	480	400	480	600	750	750	750	750	750	750	750	750	560	460	n _{1max}	4000			
T _{2S}	880	1140	1260	1000	850	1000	1250	1500	1500	1500	1500	1500	1500	1500	1500	1120	920	LpA	< 70			
J _{min}	6.2232	3.6993	2.8162	2.1069	1.7391	6.0151	5.8025	5.7092	3.4671	3.4118	2.6324	2.0320	2.0135	1.7026	1.6934	1.6864	1.6827	Lh	20000			
J _{max}	13.9214	11.3975	10.5144	9.8051	9.4373	13.7133	13.5057	13.4074	11.1653	11.1100	10.3306	9.7302	9.7117	9.4008	9.3916	9.3846	9.3809	F _{R2} (AA) F _{R2} (TT)	6500 5300			
Rt	60					50	60												50		F _{A2} (AA) F _{A2} (TT)	3250 2650
Rd	0.96					0.93												max	15'	20'		

Pag. Page Seite
14

1.6 Dimensioni

1.6 Dimensions

1.6 Abmessungen

AA

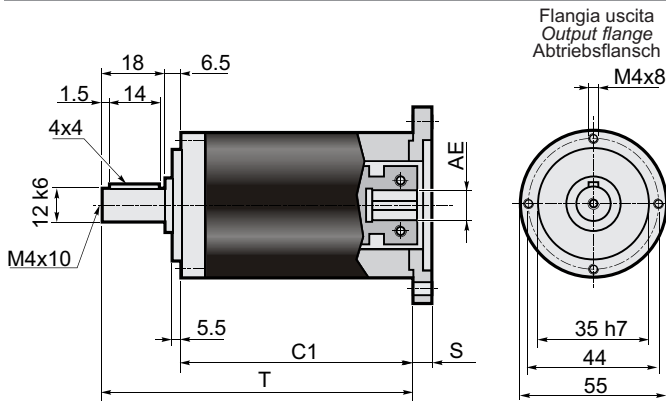

Stadi/Steps/Stufenzahl	1	2	AE= 6 - 6.35 - 7 - 8 - 9 - 9.52 - 11
C1	62.5	81.5	
T	87	106	

TT

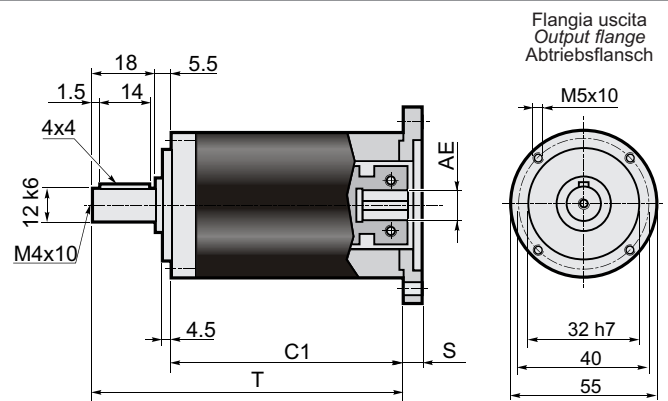

Stadi/Steps/Stufenzahl	1	2	AE= 6 - 6.35 - 7 - 8 - 9 - 9.52 - 11
C1	63.5	82.5	
T	87	106	

AQ

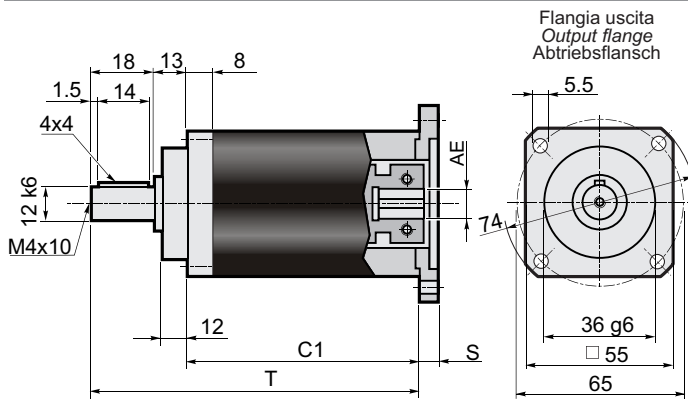

Stadi/Steps/Stufenzahl	1	2	AE= 6 - 6.35 - 7 - 8 - 9 - 9.52 - 11
C1	56	75	
T	87	106	

TQ

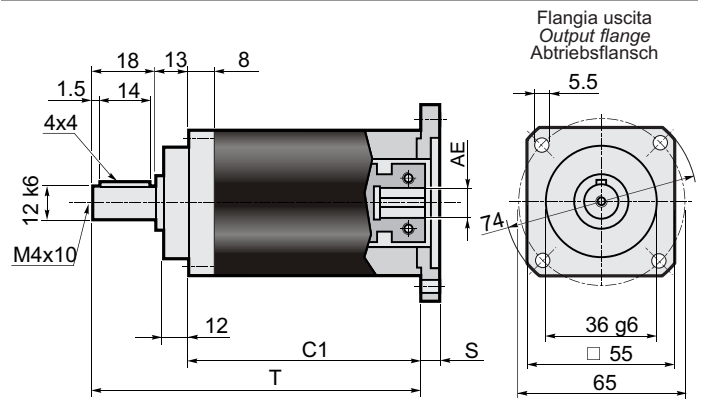

Stadi/Steps/Stufenzahl	1	2	AE= 6 - 6.35 - 7 - 8 - 9 - 9.52 - 11
C1	56	75	
T	87	106	

Dati tecnici / Technical data / Technische Daten

EP 55

Stadi Steps Stufenzahl	1																2																Stadi Steps Stufenzahl	1	2
	3	4	5	7	10	9	12	15	16	20	25	28	35	40	50	70	100																		
i	12	14	16	12	10	14	16	16	16	16	16	16	16	16	14	12	n_{1nom}	4000																	
T_{2A}	22	24	24	22	20	24	28	28	28	28	28	28	28	28	24	22	n_{1max}	5000																	
T_{2S}	44	48	48	44	40	48	56	56	56	56	56	56	56	56	48	44	LpA	< 70																	
J_{min}	0.0736	0.0626	0.0587	0.0553	0.0536	0.0734	0.0722	0.0718	0.0620	0.0617	0.0580	0.0552	0.0551	0.0536	0.0536	0.0535	0.0535	Lh	20000																
J_{max}	0.0909	0.0799	0.0759	0.0726	0.0709	0.0906	0.0894	0.0889	0.0791	0.0789	0.0751	0.0723	0.0722	0.0707	0.0707	0.0707	0.0706	F_{R2}	300																
Rt	1.0				0.9	1.0											0.9	F_{A2}	450																
Rd	0.96					0.93																max	15'	20'											

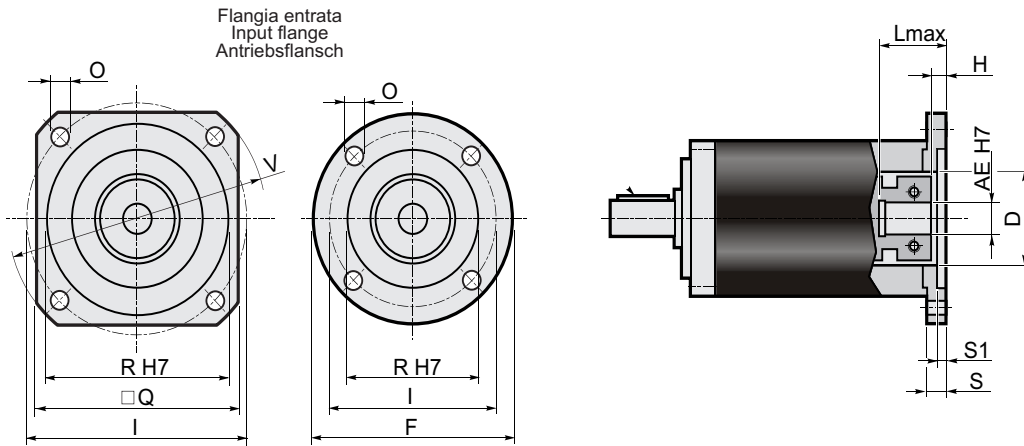

	Flange entrata / Input flange / Antriebsflansch									Albero entrata / Input shaft / Antriebswelle													
										AE													
										6		6.35		7		8		9		9.52		11	
F	Q	V	I	R (H7)	O	S	S1	D	L _{max}	H	L _{max}	H	L _{max}	H	L _{max}	H	L _{max}	H	L _{max}	H	L _{max}	H	
P01*	60	=	=	43.82	22	4.5	10	3	22	30	7	30	7	30	7	30	7	30	7	30	7	30	7
P02*	=	60	80	66.67	38.1	5.5	10	3	32	30	7	30	7	30	7	30	7	30	7	30	7	30	7
P03*	=	60	80	63	40	5.5	10	3.5	32	30	7	30	7	30	7	30	7	30	7	30	7	30	7
P04	=	70	90	75	60	6.5	10.5	3.5	32	30.5	7.5	30.5	7.5	30.5	7.5	30.5	7.5	30.5	7.5	30.5	7.5	30.5	7.5
P05	105	=	=	85	70	6.5	10.5	3.5	32	30.5	7.5	30.5	7.5	30.5	7.5	30.5	7.5	30.5	7.5	30.5	7.5	30.5	7.5
P06	=	80	110	98.42	73.02	6	11	3.5	35	31	8	31	8	31	8	31	8	31	8	31	8	31	8
P07	=	95	120	100	80	6.5	11.5	4	32	31.5	8.5	31.5	8.5	31.5	8.5	31.5	8.5	31.5	8.5	31.5	8.5	31.5	8.5
P08	=	98	130	115	95	9	11.5	4	32	31.5	8.5	31.5	8.5	31.5	8.5	31.5	8.5	31.5	8.5	31.5	8.5	31.5	8.5
P09	=	116	160	130	110	9	12	4.5	32	32	9	32	9	32	9	32	9	32	9	32	9	32	9
P10*	60	=	=	39	26	4.5	10	3	26	30	7	30	7	30	7	30	7	30	7	30	7	30	7
P11*	60	=	=	42	32	4.5	10	3	32	30	7	30	7	30	7	30	7	30	7	30	7	30	7
P12*	65	=	=	46	32	4.5	10	3.5	32	30	7	30	7	30	7	30	7	30	7	30	7	30	7
P13*	80	=	=	65	50	5.5	10	3.5	32	30	7	30	7	30	7	30	7	30	7	30	7	30	7
P14*	60	=	=	39	20	4.5	10	2.5	20	30	7	30	7	30	7	30	7	30	7	30	7	30	7
P15	=	75	100	90	60	5.8	12	3.5	32	32	9	32	9	32	9	32	9	32	9	32	9	32	9
P16*	60	=	=	45	30	3.5	14	7	30	34	11	34	11	34	11	34	11	34	11	34	11	34	11
P17	=	60	82	70	50	4.5	16.5	8	32	36.5	13.5	36.5	13.5	36.5	13.5	36.5	13.5	36.5	13.5	36.5	13.5	36.5	13.5
P18	=	60	80	60	50	M4	10.5	3.5	32	30.5	7.5	30.5	7.5	30.5	7.5	30.5	7.5	30.5	7.5	30.5	7.5	30.5	7.5
P19*	60	=	=	36	25	4.5	10	3	25	30	7	30	7	30	7	30	7	30	7	30	7	30	7
P20	=	60	82	70	50	5.5	10.5	3.5	32	30.5	7.5	30.5	7.5	30.5	7.5	30.5	7.5	30.5	7.5	30.5	7.5	30.5	7.5
P21*	60	=	=	46	30	4.5	10	3	30	30	7	30	7	30	7	30	7	30	7	30	7	30	7
P22	=	60	80	70.71	36	4.5	10	2	32	30	7	30	7	30	7	30	7	30	7	30	7	30	7
P23	=	62	85	70	50	5.5	15.5	3.5	32	35.5	12.5	35.5	12.5	35.5	12.5	35.5	12.5	35.5	12.5	35.5	12.5	35.5	12.5
P24	=	75	100	90	70	5.8	12	3.5	32	32	9	32	9	32	9	32	9	32	9	32	9	32	9
P25	=	70	95	85	55	5.8	12	3.5	32	32	9	32	9	32	9	32	9	32	9	32	9	32	9
P26*	=	60	80	65.5	34	5.5	10	3.5	33	30	7	30	7	30	7	30	7	30	7	30	7	30	7
P27	=	80	110	95	50	6.5	12	3.5	32	32	9	32	9	32	9	32	9	32	9	32	9	32	9
P28	=	60	80	66.67	38.1	M4	9	2.5	32	29	6	29	6	29	6	29	6	29	6	29	6	29	6
P29	60	=	=	45	30	M3	11	4	32	31	8	31	8	31	8	31	8	31	8	31	8	31	8
P30	=	70	95	85	60	5.8	12	3.5	32	32	9	32	9	32	9	32	9	32	9	32	9	32	9
P31	=	62	85	70	50	M4	11	3.5	32	31	8	31	8	31	8	31	8	31	8	31	8	31	8
P32	=	60	80	65	40	M5	10	3.5	32	30	7	30	7	30	7	30	7	30	7	30	7	30	7
P33	=	85	115	99	60	5.5	11	3.5	35	31	8	31	8	31	8	31	8	31	8	31	8	31	8
P34	=	65	87	73.54	40	M4	10	3.5	32	30	7	30	7	30	7	30	7	30	7	30	7	30	7
P35	=	60	80	70.71	36	M4	14	2	32	34	11	34	11	34	11	34	11	34	11	34	11	34	11
P36	=	85	115	98.42	73.02	6	15	3.5	35	35	12	35	12	35	12	35	12	35	12	35	12	35	12

* Per assemblare il motore è necessario smontare la flangia dal riduttore (vedere schema di montaggio 2 a pag. 17).

* To mount the motor it is necessary to remove the gearbox flange (see assembly drawing 2 on page 17).

* Vor dem Einbauen des Motors soll die Getriebeflange abmontiert werden (siehe Bauanleitung 2 auf Seite 17).

AA

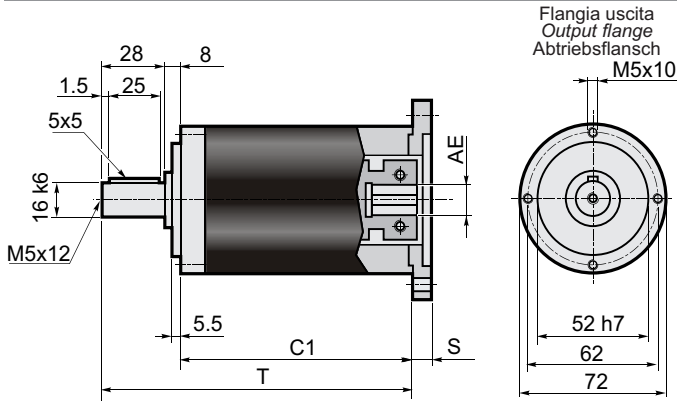

Stadi/Steps/Stufenzahl	1	2	AE= 6-6.35-7-8-9-9.52-11-12-12.7-14
C1	78.5	101	
T	114.5	137	

TT

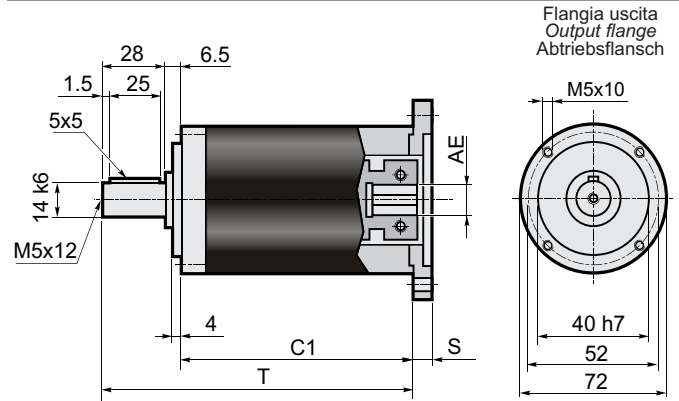

Stadi/Steps/Stufenzahl	1	2	AE= 6-6.35-7-8-9-9.52-11-12-12.7-14
C1	80	102.5	
T	114.5	137	

AQ

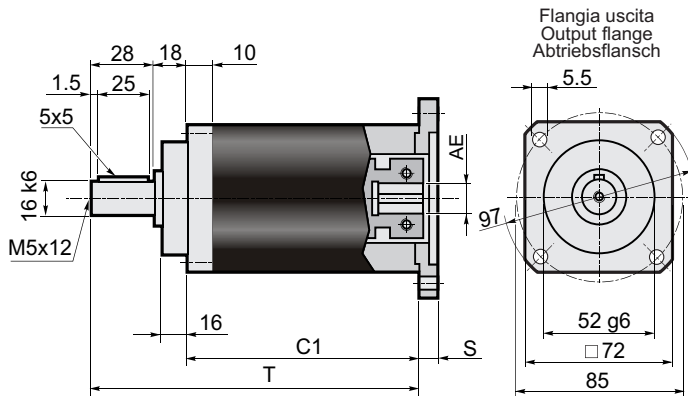

Stadi/Steps/Stufenzahl	1	2	AE= 6-6.35-7-8-9-9.52-11-12-12.7-14
C1	68.5	91	
T	114.5	137	

TQ

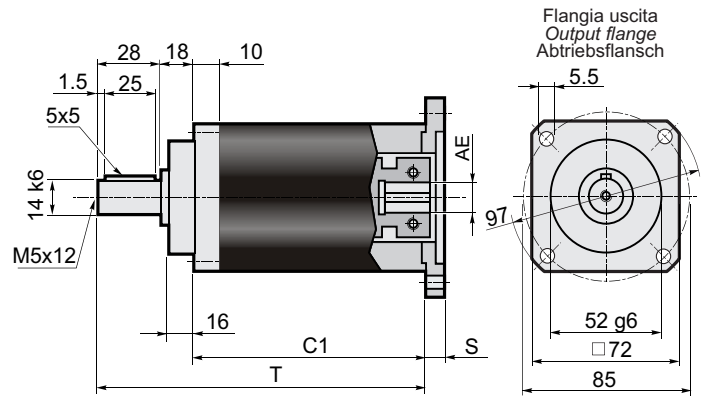

Stadi/Steps/Stufenzahl	1	2	AE= 6-6.35-7-8-9-9.52-11-12-12.7-14
C1	68.5	91	
T	114.5	137	

Dati tecnici / Technical data / Technische Daten

EP 75

Stadi Steps Stufenzahl	1																2																Stadi Steps Stufenzahl	1		2	
	3	4	5	7	10	9	12	15	16	20	25	28	35	40	50	70	100	1	2	1	2																
T_{2N}	22	28	32	28	20	26	32	36	36	36	36	36	36	36	36	30	22	n_{1nom}	4000																		
T_{2A}	40	45	50	45	40	50	60	60	60	60	60	60	60	60	60	50	45	n_{1max}	5000																		
T_{2S}	80	90	100	90	80	100	120	120	120	120	120	120	120	120	120	100	90	LpA	< 70																		
J_{min}	0.1707	0.1163	0.1063	0.0927	0.0860	0.1597	0.1549	0.1538	0.1159	0.1153	0.1017	0.0927	0.0925	0.0860	0.0859	0.0857	0.0857	Lh	20000																		
J_{max}	0.2166	0.1622	0.1522	0.1386	0.1319	0.2056	0.2008	0.1997	0.1618	0.1612	0.1476	0.1386	0.1384	0.1319	0.1318	0.1316	0.1316	F_{R2}	1800																		
Rt	3.5				3.0	3.5											3.0	F_{A2}	1400																		
Rd	0.96				0.93													max	15'	20'																	

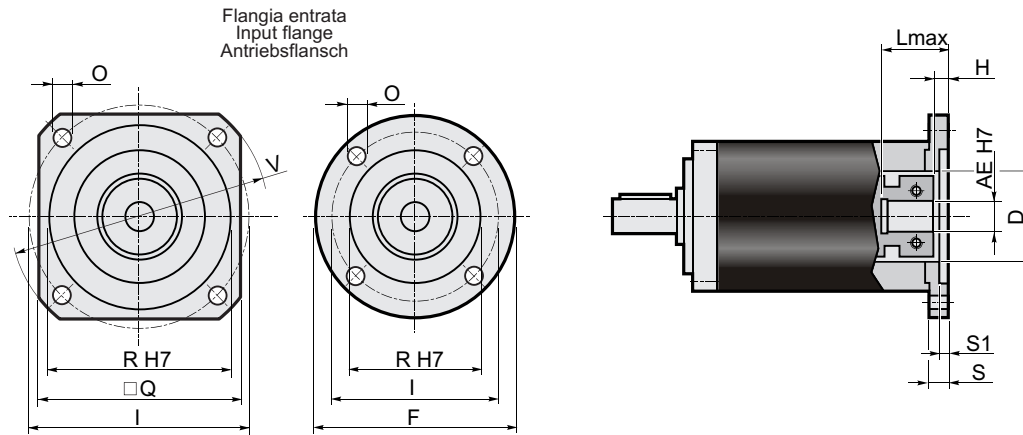

Flange entrata / Input flange / Antriebsflansch										Albero entrata / Input shaft / Antriebswelle																	
										AE																	
										6		6.35		7		8		9		9.52		11		12		12.7	
F	Q	V	I	R (H7)	O	S	S1	D	L _{max}	H	L _{max}	H	L _{max}	H	L _{max}	H	L _{max}	H	L _{max}	H	L _{max}	H	L _{max}	H			
P01*	60	=	=	43.82	22	4.5	10	3	22	35	4.5	35	4.5	35	4.5	26	6.5	26	6.5	35	6.5	26	6.5	35	6.5	35	6.5
P02*	=	60	80	66.67	38.1	5.5	10	3	32	35	4.5	35	4.5	35	4.5	26	6.5	26	6.5	35	6.5	26	6.5	35	6.5	35	6.5
P03*	=	60	80	63	40	5.5	10	3.5	32	35	4.5	35	4.5	35	4.5	26	6.5	26	6.5	35	6.5	26	6.5	35	6.5	35	6.5
P04	=	70	90	75	60	6.5	10.5	3.5	32	35.5	5	35.5	5	35.5	5	26.5	7	26.5	7	35.5	7	26.5	7	35.5	7	35.5	7
P05	105	=	=	85	70	6.5	10.5	3.5	32	35.5	5	35.5	5	35.5	5	26.5	7	26.5	7	35.5	7	26.5	7	35.5	7	35.5	7
P06	=	80	110	98.42	73.02	6	11	3.5	35	36	5.5	36	5.5	36	5.5	27	7.5	27	7.5	36	7.5	27	7.5	36	7.5	36	7.5
P07	=	95	120	100	80	6.5	11.5	4	32	36.5	6	36.5	6	36.5	6	27.5	8	27.5	8	36.5	8	27.5	8	36.5	8	36.5	8
P08	=	98	130	115	95	9	11.5	4	32	36.5	6	36.5	6	36.5	6	27.5	8	27.5	8	36.5	8	27.5	8	36.5	8	36.5	8
P09	=	116	160	130	110	9	12	4.5	32	37	6.5	37	6.5	37	6.5	28	8.5	28	8.5	37	8.5	28	8.5	37	8.5	37	8.5
P10*	60	=	=	39	26	4.5	10	3	26	35	4.5	35	4.5	35	4.5	26	6.5	26	6.5	35	6.5	26	6.5	35	6.5	35	6.5
P11*	60	=	=	42	32	4.5	10	3	32	35	4.5	35	4.5	35	4.5	26	6.5	26	6.5	35	6.5	26	6.5	35	6.5	35	6.5
P12*	65	=	=	46	32	4.5	10	3.5	32	35	4.5	35	4.5	35	4.5	26	6.5	26	6.5	35	6.5	26	6.5	35	6.5	35	6.5
P13*	80	=	=	65	50	5.5	10	3.5	32	35	4.5	35	4.5	35	4.5	26	6.5	26	6.5	35	6.5	26	6.5	35	6.5	35	6.5
P14*	60	=	=	39	20	4.5	10	2.5	20	35	4.5	35	4.5	35	4.5	26	6.5	26	6.5	35	6.5	26	6.5	35	6.5	35	6.5
P15	=	75	100	90	60	5.8	12	3.5	32	37	6.5	37	6.5	37	6.5	28	8.5	28	8.5	37	8.5	28	8.5	37	8.5	37	8.5
P16*	60	=	=	45	30	3.5	14	7	30	39	8.5	39	8.5	39	8.5	30	10.5	30	10.5	39	10.5	30	10.5	39	10.5	39	10.5
P17	=	60	82	70	50	4.5	16.5	8	32	41.5	11	41.5	11	41.5	11	32.5	13	32.5	13	41.5	13	32.5	13	41.5	13	41.5	13
P18	=	60	80	60	50	M4	10.5	3.5	32	35.5	5	35.5	5	35.5	5	26.5	7	26.5	7	35.5	7	26.5	7	35.5	7	35.5	7
P19*	60	=	=	36	25	4.5	10	3	25	35	4.5	35	4.5	35	4.5	26	6.5	26	6.5	35	6.5	26	6.5	35	6.5	35	6.5
P20	=	60	82	70	50	5.5	10.5	3.5	32	35.5	5	35.5	5	35.5	5	26.5	7	26.5	7	35.5	7	26.5	7	35.5	7	35.5	7
P21*	60	=	=	46	30	4.5	10	3	30	35	4.5	35	4.5	35	4.5	26	6.5	26	6.5	35	6.5	26	6.5	35	6.5	35	6.5
P22	=	60	80	70.71	36	4.5	10	2	32	35	4.5	35	4.5	35	4.5	26	6.5	26	6.5	35	6.5	26	6.5	35	6.5	35	6.5
P23	=	62	85	70	50	5.5	15.5	3.5	32	40.5	10	40.5	10	40.5	10	31.5	12	31.5	12	40.5	12	31.5	12	40.5	12	40.5	12
P24	=	75	100	90	70	5.8	12	3.5	32	37	6.5	37	6.5	37	6.5	28	8.5	28	8.5	37	8.5	28	8.5	37	8.5	37	8.5
P25	=	70	95	85	55	5.8	12	3.5	32	37	6.5	37	6.5	37	6.5	28	8.5	28	8.5	37	8.5	28	8.5	37	8.5	37	8.5
P26*	=	60	80	65.5	34	5.5	10	3.5	33	35	4.5	35	4.5	35	4.5	26	6.5	26	6.5	35	6.5	26	6.5	35	6.5	35	6.5
P27	=	80	110	95	50	6.5	12	3.5	32	37	6.5	37	6.5	37	6.5	28	8.5	28	8.5	37	8.5	28	8.5	37	8.5	37	8.5
P28	=	60	80	66.67	38.1	M4	9	2.5	32	34	3.5	34	3.5	34	3.5	25	5.5	25	5.5	34	5.5	25	5.5	34	5.5	34	5.5
P29	60	=	=	45	30	M3	11	4	32	36	5.5	36	5.5	36	5.5	27	7.5	27	7.5	36	7.5	27	7.5	36	7.5	36	7.5
P30	=	70	95	85	60	5.8	12	3.5	32	37	6.5	37	6.5	37	6.5	28	8.5	28	8.5	37	8.5	28	8.5	37	8.5	37	8.5
P31	=	62	85	70	50	M4	11	3.5	32	36	5.5	36	5.5	36	5.5	27	7.5	27	7.5	36	7.5	27	7.5	36	7.5	36	7.5
P32	=	60	80	65	40	M5	10	3.5	32	35	4.5	35	4.5	35	4.5	26	6.5	26	6.5	35	6.5	26	6.5	35	6.5	35	6.5
P33	=	85	115	99	60	5.5	11	3.5	32	36	5.5	36	5.5	36	5.5	27	7.5	27	7.5	36	7.5	27	7.5	36	7.5	36	7.5
P34	=	65	87	73.54	40	M4	10	3.5	32	35	4.5	35	4.5	35	4.5	26	6.5	26	6.5	35	6.5	26	6.5	35	6.5	35	6.5
P35	=	60	80	70.71	36	M4	14	2	32	39	8.5	39	8.5	39	8.5	30	10.5	30	10.5	39	10.5	30	10.5	39	10.5	39	10.5
P36	=	85	115	98.42	73.02	6	15	3.5	35	40	9.5	40	9.5	40	9.5	35	11.5	31	11.5	40	11.5	35	11.5	40	11.5	40	11.5

* Per assemblare il motore è necessario smontare la flangia dal riduttore (vedere schema di montaggio 2 a pag. 17).

* To mount the motor it is necessary to remove the gearbox flange (see assembly drawing 2 on page 17).

* Vor dem Einbauen des Motors soll die Getriebeflangens abmontiert werden (siehe Bauanleitung 2 auf Seite 17).

AA

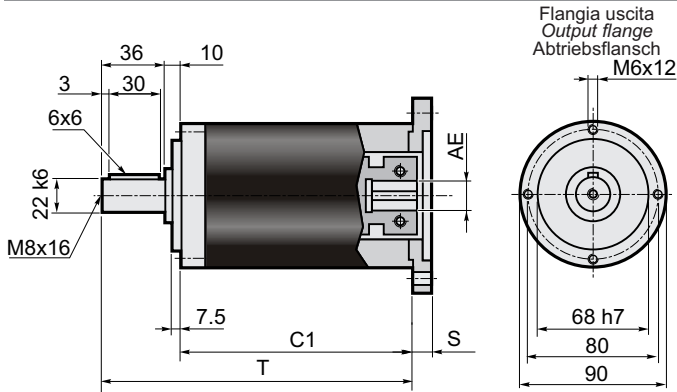

Stadi/Steps/Stufenzahl	1	2	9-9.52-11-12-12.7-14-15.87-16-19	AE=
C1	98	127		
T	144	173		

TT

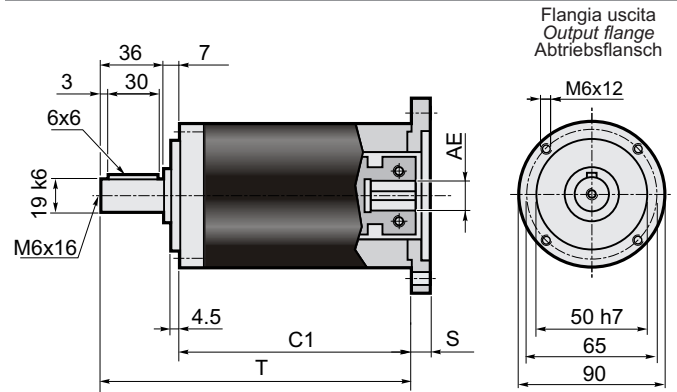

Stadi/Steps/Stufenzahl	1	2	9-9.52-11-12-12.7-14-15.87-16-19	AE=
C1	101	130		
T	144	173		

AQ

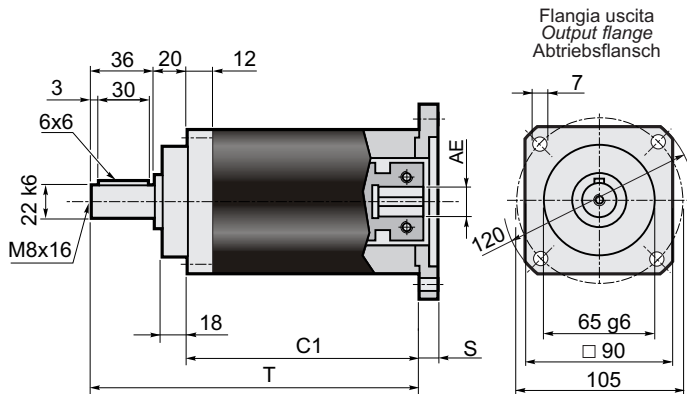

Stadi/Steps/Stufenzahl	1	2	9-9.52-11-12-12.7-14-15.87-16-19	AE=
C1	88	117		
T	144	173		

TQ

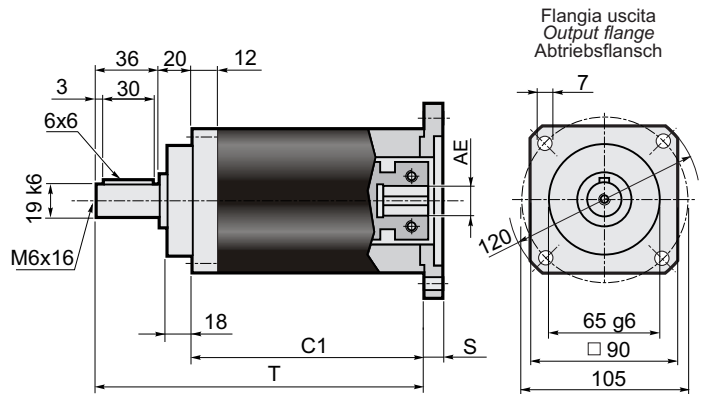

Stadi/Steps/Stufenzahl	1	2	9-9.52-11-12-12.7-14-15.87-16-19	AE=
C1	88	117		
T	144	173		

Dati tecnici / Technical data / Technische Daten

EP 90																		Stadi Steps Stufenzahl		
Stadi Steps Stufenzahl	1					2												1	2	
	3	4	5	7	10	9	12	15	16	20	25	28	35	40	50	70	100			
T_{2N}	50	55	60	55	50	65	70	75	75	75	75	75	75	75	75	65	55	n_{1nom}	4000	
T_{2A}	80	90	100	90	80	100	110	120	120	120	120	120	120	120	120	100	90	n_{1max}	5000	
T_{2S}	160	180	200	180	160	200	220	240	240	240	240	240	240	240	240	200	180	LpA	< 70	
J_{min}	0.5159	0.3371	0.2742	0.2247	0.2008	0.5193	0.4995	0.4925	0.3272	0.3233	0.2651	0.2215	0.2202	0.1992	0.1985	0.1980	0.1978	Lh	20000	
J_{max}	0.7271	0.5483	0.4854	0.4359	0.4120	0.7305	0.7305	0.7036	0.5384	0.5345	0.4763	0.4326	0.4314	0.4103	0.4097	0.4092	0.4090	F_{R2}	2600	
Rt	9.0				7.5	9.0											7.5	F_{A2}	2000	
Rd	0.96					0.93												max	15'	20'

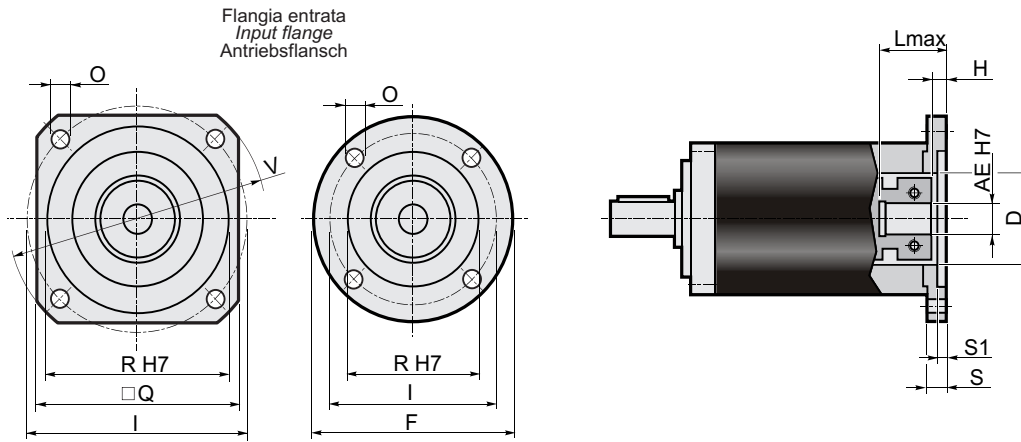

Flange entrata / Input flange / Antriebsflansch										Albero entrata - Input shaft - Antriebswelle															
										AE															
F	Q	V	I	R (H7)	O	S	S1	D	L _{max}	H	L _{max}	H	L _{max}	H	L _{max}	H	L _{max}	H	L _{max}	H	L _{max}	H	L _{max}	H	
P01*	80	=	=	66.67	38.1	5.5	12	3	38.1	44	6.5	44	9	29	9	44	9	44	9	44	9	44	9	44	9
P02	=	106.5	140	125.72	55.52	7	11	3	45	43	5.5	43	8	28	8	43	8	43	8	43	8	43	8	43	8
P03*	=	80	90	75	60	5.5	12	3.5	45	44	6.5	44	9	29	9	44	9	44	9	44	9	44	9	44	9
P04*	105	=	=	85	70	6.5	12	3.5	45	44	6.5	44	9	29	9	44	9	44	9	44	9	44	9	44	9
P05	=	82.5	110	98.425	73.02	6.5	12	3	45	44	6.5	44	9	29	9	44	9	44	9	44	9	44	9	44	9
P06	=	90	120	100	80	6.5	13	4	45	45	7.5	45	10	30	10	45	10	45	10	45	10	45	10	45	10
P07	=	100	135	115	95	8.5	13	4.5	45	45	7.5	45	10	30	10	45	10	45	10	45	10	45	10	45	10
P08	=	116	160	130	110	9	13	4.5	45	45	7.5	45	10	30	10	45	10	45	10	45	10	45	10	45	10
P09*	80	=	=	39	26	4.5	12	4	26	44	6.5	44	9	29	9	44	9	44	9	44	9	44	9	44	9
P10*	80	=	=	65	50	5.5	12	3.5	45	44	6.5	44	9	29	9	44	9	44	9	44	9	44	9	44	9
P11	=	150	182	166	115	9	32	11	50x14	64	26.5	64	29	49	29	64	29	64	29	64	29	64	29	64	29
P12*	=	80	105	90	70	6.5	12	3.5	32	44	6.5	44	9	29	9	44	9	44	9	44	9	44	9	44	9
P14*	105	=	=	90	70	6	19	9	32	51	13.5	51	16	36	16	51	16	51	16	51	16	51	16	51	16
P15*	80	=	=	70	50	4.5	17	8	45	49	11.5	49	14	34	14	49	14	49	14	49	14	49	14	49	14
P16	=	142	190	165	130	11	13	4.5	45	45	7.5	45	10	30	10	45	10	45	10	45	10	45	10	45	10
P17*	80	=	=	63	40	5.5	12	3.5	40	44	6.5	44	9	29	9	44	9	44	9	44	9	44	9	44	9
P18	=	130	170	145	110	M8	31	7	32	63	25.5	63	28	48	28	63	28	63	28	63	28	63	28	63	28
P19*	=	80	105	90	60	6.5	12	3.5	32	44	6.5	44	9	29	9	44	9	44	9	44	9	44	9	44	9
P20*	=	80	105	85	55	5.5	12	3.5	36	44	6.5	44	9	29	9	44	9	44	9	44	9	44	9	44	9
P21	=	80	110	95	50	M6	12	3.5	45	44	6.5	44	9	29	9	44	9	44	9	44	9	44	9	44	9
P22	80	=	=	70	50	M4	12	4	45	44	6.5	44	9	29	9	44	9	44	9	44	9	44	9	44	9
P23	=	80	90	75	60	M5	12	3.5	45	44	6.5	44	9	29	9	44	9	44	9	44	9	44	9	44	9
P24	80	=	=	46	30	M4	12	4	30	44	6.5	44	9	29	9	44	9	44	9	44	9	44	9	44	9
P26	80	=	=	65	40	M5	12	3.5	40	44	6.5	44	9	29	9	44	9	44	9	44	9	44	9	44	9
P27	=	80	105	82.02	36.8	M6	14	10	36.8	46	8.5	46	11	31	11	46	11	46	11	46	11	46	11	46	11
P28	=	90	120	100	80	6.5	28	4	45	60	22.5	60	25	45	25	60	25	60	25	60	25	60	25	60	25
P29	80	=	=	66.67	50	5.5	12	3	45	44	6.5	44	9	29	9	44	9	44	9	44	9	44	9	44	9
P30	=	115	155	130	80	9	13	4	45	45	7.5	45	10	30	10	45	10	45	10	45	10	45	10	45	10
P31	=	80	105	56	44	M6	14	10	36.8	46	8.5	46	11	31	11	46	11	46	11	46	11	46	11	46	11
P33	=	130	165	145	110	9	13	4.5	45	45	7.5	45	10	30	10	45	10	45	10	45	10	45	10	45	10

* Per assemblare il motore è necessario smontare la flangia dal riduttore (vedere schema di montaggio 2 a pag. 17).

* To mount the motor it is necessary to remove the gearbox flange (see assembly drawing 2 on page 17).

* Vor dem Einbauen des Motors soll die Getriebeflangsch abmontiert werden (siehe Bauanleitung 2 auf Seite 17).

AA

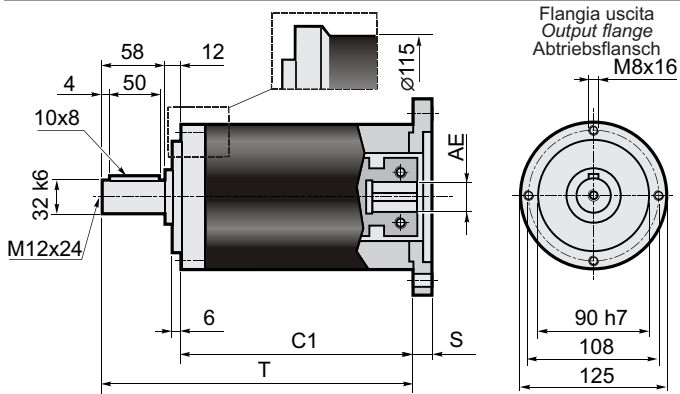

Stadi/Steps/Stufenzahl	1	2	
C1	115.8	148.4	AE= 12.7-14-15.87-16-19
T	185.8	218.4	
C1	134.8	167.4	AE= 22-24-28
T	204.8	237.4	

TT

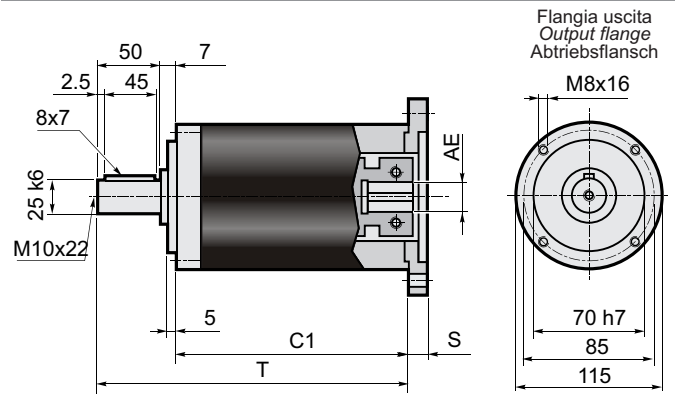

Stadi/Steps/Stufenzahl	1	2	
C1	120.8	153.4	AE= 12.7-14-15.87-16-19
T	177.8	210.4	
C1	139.8	172.4	AE= 22-24-28
T	196.8	229.4	

AQ

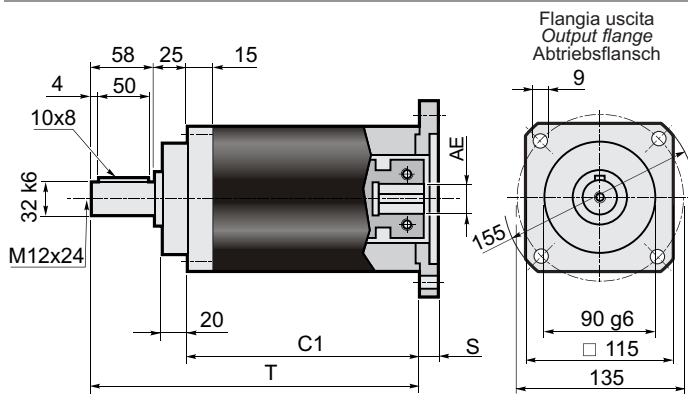

Stadi/Steps/Stufenzahl	1	2	
C1	102.8	135.4	AE= 12.7-14-15.87-16-19
T	185.8	218.4	
C1	121.8	154.4	AE= 22-24-28
T	204.8	237.4	

TQ

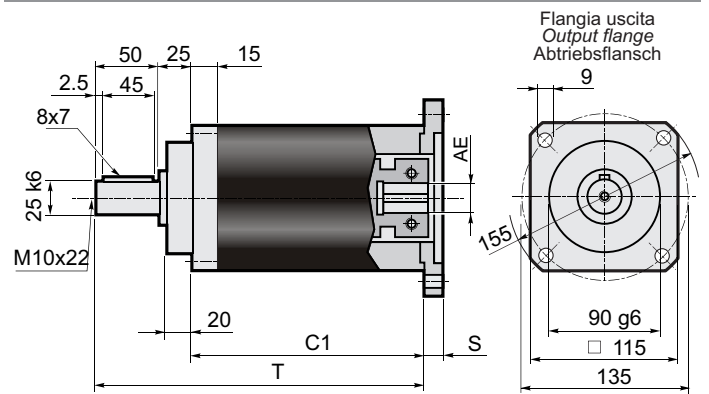

Stadi/Steps/Stufenzahl	1	2	
C1	102.8	135.4	AE= 12.7-14-15.87-16-19
T	177.8	210.4	
C1	121.8	154.4	AE= 22-24-28
T	196.8	229.4	

Dati tecnici / Technical data / Technische Daten

EP 120																		Stadi Steps Stufenzahl	
Stadi Steps Stufenzahl	1					2													
i	3	4	5	7	10	9	12	15	16	20	25	28	35	40	50	70	100	1	2
T_{2N}	120	150	180	150	100	150	180	220	220	220	220	220	220	220	220	170	110	n_{1nom}	3000
T_{2A}	190	240	290	220	180	240	290	350	350	350	350	350	350	350	350	270	200	n_{1max}	4000
T_{2S}	400	500	600	460	380	500	600	700	700	700	700	700	700	700	700	540	400	LpA	< 70
J_{min}	2.0027	1.1339	0.8557	0.6244	0.5047	1.9802	1.8962	1.8552	1.0736	1.0505	0.8023	0.6048	0.5977	0.4951	0.4918	0.4895	0.4883	Lh	20000
J_{max}	4.1528	3.2840	3.0058	2.7745	2.6548	3.1885	3.1045	3.0636	2.2819	2.2589	2.0106	1.8132	1.8061	1.7035	1.7002	1.6979	1.6967	F_{R2}	4500
Rt	32				28	32	30					28					F_{A2}	4000	
Rd	0.96					0.93											max	15'	20'

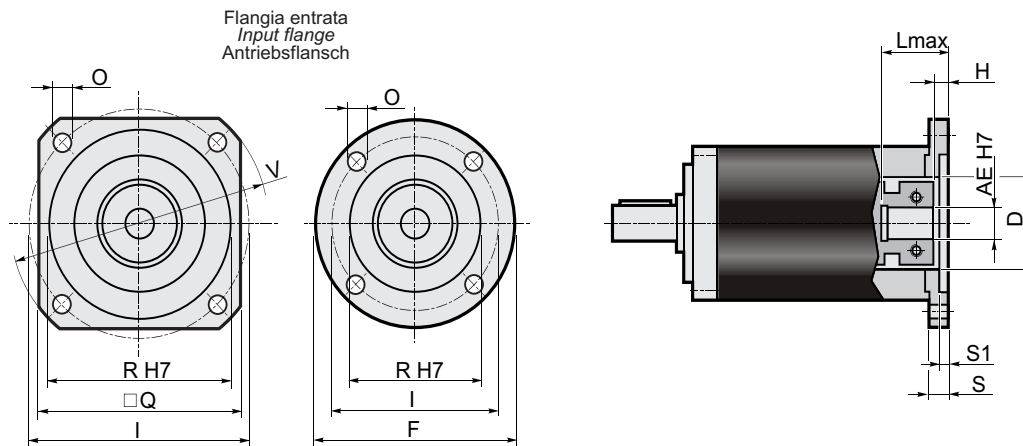

Flange entrata / Input flange / Antriebsflansch										Albero entrata - Input shaft - Antriebswelle															
										AE															
										12.7		14		15.87		16		19		22		24		28	
F	Q	V	I	R (H7)	O	S	S1	D	L _{max}	H	L _{max}	H	L _{max}	H	L _{max}	H	L _{max}	H	L _{max}	H	L _{max}	H	L _{max}	H	
P01*	=	115	140	125.72	55.52	6.5	13	3	55.52	43	6	35	6	43	6	43	6	43	6	62	6	62	6	62	6
P02*	115	=	=	75	60	5.5	13	3.5	60	43	6	35	6	43	6	43	6	43	6	62	6	62	6	62	6
P03*	115	=	=	85	70	6.5	13	3.5	60	43	6	35	6	43	6	43	6	43	6	62	6	62	6	62	6
P04*	115	=	=	98.42	73.02	6.5	13	3	60	43	6	35	6	43	6	43	6	43	6	62	6	62	6	62	6
P05*	120	=	=	100	80	6.5	13	4	60	43	6	35	6	43	6	43	6	43	6	62	6	62	6	62	6
P06*	=	115	140	115	95	9	13	4.5	60	43	6	35	6	43	6	43	6	43	6	62	6	62	6	62	6
P07	=	115	160	130	110	8.5	13	4.5	60	43	6	35	6	43	6	43	6	43	6	62	6	62	6	62	6
P08	=	142	190	165	130	11	13	4.5	60	43	6	35	6	43	6	43	6	43	6	62	6	62	6	62	6
P09	=	192	250	215	180	13	14	4.5	60	44	7	36	7	44	7	44	7	44	7	63	7	63	7	63	7
P10*	115	=	=	65	50	6.5	13	3.5	50	43	6	35	6	43	6	43	6	43	6	62	6	62	6	62	6
P11	=	130	170	145	110	M 8	31	7	60	61	24	53	24	61	24	61	24	61	24	80	24	80	24	80	24
P12	=	130	170	145	110	M 8	17	7	60	47	10	39	10	47	10	47	10	47	10	66	10	66	10	66	10
P13	=	115	160	130	110	M 8	13	4.5	60	43	6	35	6	43	6	43	6	43	6	62	6	62	6	62	6
P14*	115	=	=	70	50	6.5	13	3.5	50	43	6	35	6	43	6	43	6	43	6	62	6	62	6	62	6
P15	115	=	=	90	70	M5	11	3.5	60	41	4	33	4	41	4	41	4	41	4	60	4	60	4	60	4
P17*	115	=	=	90	70	6.5	13	3.5	60	43	6	35	6	43	6	43	6	43	6	62	6	62	6	62	6
P18	=	115	155	130	95	8.5	13	4.5	60	43	6	35	6	43	6	43	6	43	6	62	6	62	6	62	6
P19*	115	=	=	95	50	6.5	13	3.5	50	43	6	35	6	43	6	43	6	43	6	62	6	62	6	62	6
P20	115	=	=	99	60	M6	13	4	60	43	6	35	6	43	6	43	6	43	6	62	6	62	6	62	6
P21	130	=	=	106	82.5	12.5	26.5	15	60	56.5	19.5	48.5	19.5	56.5	19.5	56.6	19.5	56.5	19.5	75.5	19.5	75.5	19.5	75.5	19.5

* Per assemblare il motore è necessario smontare la flangia dal riduttore (vedere schema di montaggio 2 a pag. 17).

* To mount the motor it is necessary to remove the gearbox flange (see assembly drawing 2 on page 17).

* Vor dem Einbauen des Motors soll die Getriebeflange abmontiert werden (siehe Bauanleitung 2 auf Seite 17).

AA

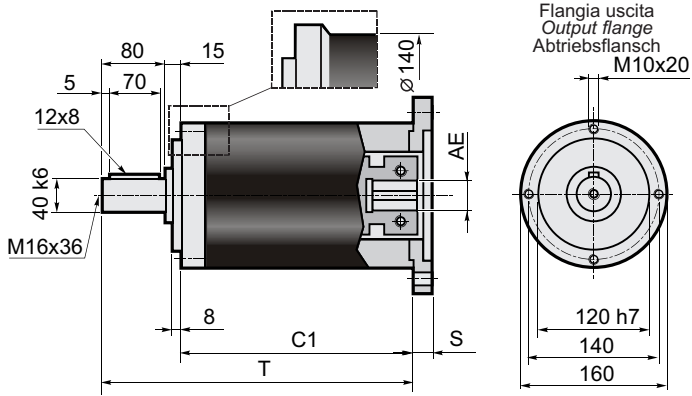

Stadi/Steps/Stufenzahl	1	2	
C1	156	197.5	AE= 15.87-16-19-22-24
T	251	292.5	
C1	181	222.5	AE= 28-32-35-38
T	276	317.5	

TT

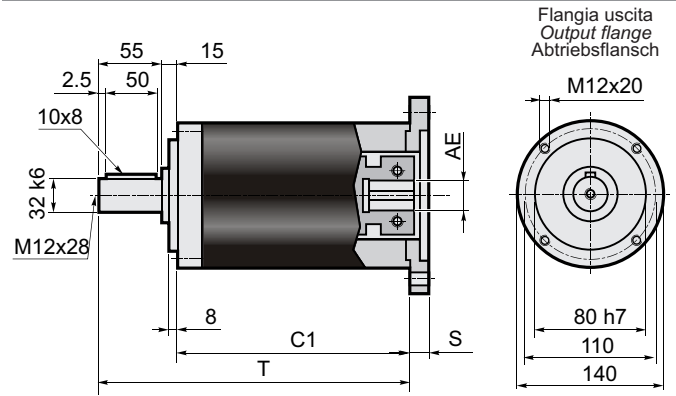

Stadi/Steps/Stufenzahl	1	2	
C1	156	197.5	AE= 15.87-16-19-22-24
T	226	267.5	
C1	181	222.5	AE= 28-32-35-38
T	251	292.5	

AQ

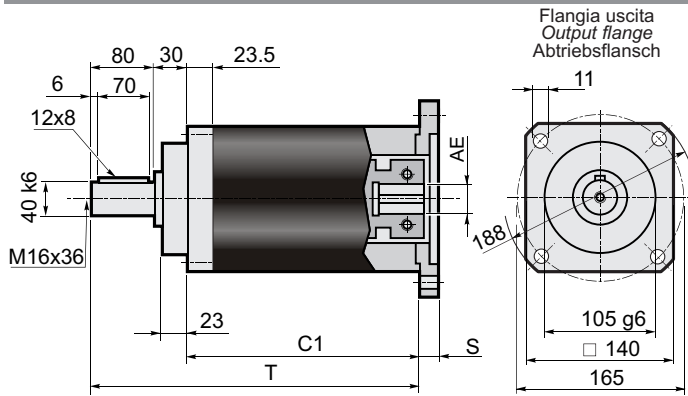

Stadi/Steps/Stufenzahl	1	2	
C1	141	182.5	AE= 15.87-16-19-22-24
T	251	292.5	
C1	166	207.5	AE= 28-32-35-38
T	276	317.5	

Dati tecnici / Technical data / Technische Daten

EP 155																		Stadi Steps Stufenzahl		
Stadi Steps Stufenzahl	1								2								1	2		
	3	4	5	7	10	9	12	15	16	20	25	28	35	40	50	70			100	
T_{2N}	240	320	380	300	220	320	400	500	500	500	500	500	500	500	500	350	250	n_{1nom}	3000	
T_{2A}	420	540	600	480	400	480	600	750	750	750	750	750	750	750	750	560	460	n_{1max}	4000	
T_{2S}	880	1140	1260	1000	850	1000	1250	1500	1500	1500	1500	1500	1500	1500	1500	1120	920	LpA	< 70	
J_{min}	6.2232	3.6993	2.8162	2.1069	1.7391	6.0151	5.8025	5.7092	3.4671	3.4118	2.6324	2.0320	2.0135	1.7026	1.6934	1.6864	1.6827	Lh	20000	
J_{max}	13.9214	11.3975	10.5144	9.8051	9.4373	13.7133	13.5057	13.4074	11.1653	11.1100	10.3306	9.7302	9.7117	9.4008	9.3916	9.3846	9.3809	F_{R2} (AA) F_{R2} (TT)	6500 5300	
Rt	60				50	60										50	F_{A2} (AA) F_{A2} (TT)	3250 2650		
Rd	0.96					0.93												max	15'	20'

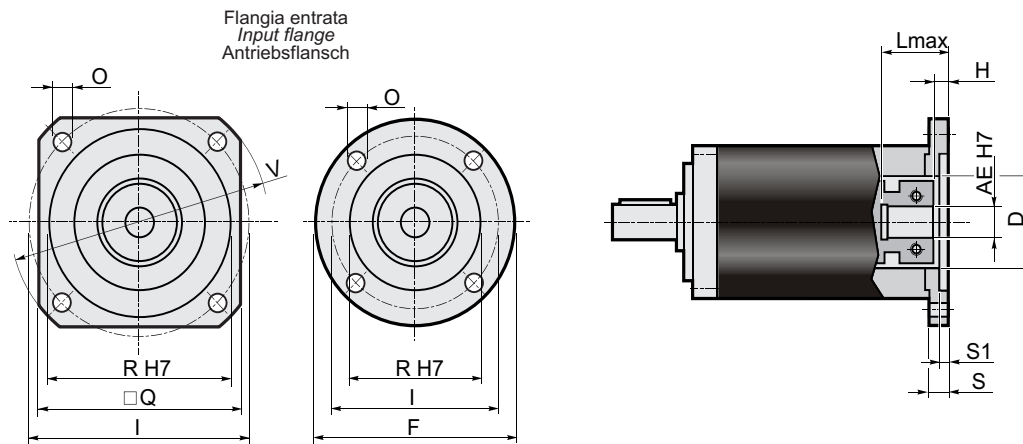

Flange entrata / Input flange / Antriebsflansch	Albero entrata - Input shaft - Antriebswelle																																
										AE																							
	F	Q	V	I	R (H7)	O	S	S1	D	15.87	16	19	22	24	28	32	35	38	L max	H	L max	H	L max	H	L max	H	L max	H	L max	H	L max	H	L max
P01*	140	=	=	125.72	55.52	6.5	15	4	55.52	57.8	6.8	57.8	6.8	42.8	6.8	57.8	6.8	57.8	6.8	82.8	7.3	82.8	7.3	82.8	7.3	82.8	7.3	82.8	7.3	82.8	7.3	82.8	7.3
P02*	140	=	=	100	80	6.5	15	4	70	57.8	6.8	57.8	6.8	42.8	6.8	57.8	6.8	57.8	6.8	82.8	7.3	82.8	7.3	82.8	7.3	82.8	7.3	82.8	7.3	82.8	7.3	82.8	7.3
P03*	140	=	=	115	95	8.5	15	4.5	70	57.8	6.8	57.8	6.8	42.8	6.8	57.8	6.8	57.8	6.8	82.8	7.3	82.8	7.3	82.8	7.3	82.8	7.3	82.8	7.3	82.8	7.3	82.8	7.3
P04*	=	140	160	130	110	8.5	15	4.5	70	57.8	6.8	57.8	6.8	42.8	6.8	57.8	6.8	57.8	6.8	82.8	7.3	82.8	7.3	82.8	7.3	82.8	7.3	82.8	7.3	82.8	7.3	82.8	7.3
P05	=	142	190	165	130	11	15	4.5	70	57.8	6.8	57.8	6.8	42.8	6.8	57.8	6.8	57.8	6.8	82.8	7.3	82.8	7.3	82.8	7.3	82.8	7.3	82.8	7.3	82.8	7.3	82.8	7.3
P06	=	190	250	215	180	13	15	4.5	70	57.8	6.8	57.8	6.8	42.8	6.8	57.8	6.8	57.8	6.8	82.8	7.3	82.8	7.3	82.8	7.3	82.8	7.3	82.8	7.3	82.8	7.3	82.8	7.3
P07	=	250	300	265	230	13	15	4.5	70	57.8	6.8	57.8	6.8	42.8	6.8	57.8	6.8	57.8	6.8	82.8	7.3	82.8	7.3	82.8	7.3	82.8	7.3	82.8	7.3	82.8	7.3	82.8	7.3
P08	=	130	165	145	110	M 8	18	7	70	60.8	9.8	60.8	9.8	45.8	9.8	60.8	9.8	60.8	9.8	85.8	10.3	85.8	10.3	85.8	10.3	85.8	10.3	85.8	10.3	85.8	10.3	85.8	10.3
P09	=	180	230	200	114.3	13.5	22	11	70	64.8	13.8	64.8	13.8	49.8	13.8	64.8	13.8	64.8	13.8	89.8	14.3	89.8	14.3	89.8	14.3	89.8	14.3	89.8	14.3	89.8	14.3	89.8	14.3
P10	=	115	150	130	95	M 8	15	4.5	70	57.8	6.8	57.8	6.8	42.8	6.8	57.8	6.8	57.8	6.8	82.8	7.3	82.8	7.3	82.8	7.3	82.8	7.3	82.8	7.3	82.8	7.3	82.8	7.3
P11	=	180	230	198	155	13.5	22	7	120x11	64.8	13.8	64.8	13.8	49.8	13.8	64.8	13.8	64.8	13.8	89.8	14.3	89.8	14.3	89.8	14.3	89.8	14.3	89.8	14.3	89.8	14.3	89.8	14.3
P12	=	220	270	235	200	13.5	15	5	70	57.8	6.8	57.8	6.8	42.8	6.8	57.8	6.8	57.8	6.8	82.8	7.3	82.8	7.3	82.8	7.3	82.8	7.3	82.8	7.3	82.8	7.3	82.8	7.3
P13	=	190	250	215	130	13	15	4.5	70	57.8	6.8	57.8	6.8	42.8	6.8	57.8	6.8	57.8	6.8	82.8	7.3	82.8	7.3	82.8	7.3	82.8	7.3	82.8	7.3	82.8	7.3	82.8	7.3
P14	=	142	190	165	110	11	15	4.5	70	57.8	6.8	57.8	6.8	42.8	6.8	57.8	6.8	57.8	6.8	82.8	7.3	82.8	7.3	82.8	7.3	82.8	7.3	82.8	7.3	82.8	7.3	82.8	7.3
P15*	150	=	=	90	70	6.5	15	4	70	57.8	6.8	57.8	6.8	42.8	6.8	57.8	6.8	57.8	6.8	82.8	7.3	82.8	7.3	82.8	7.3	82.8	7.3	82.8	7.3	82.8	7.3	82.8	7.3

* Per assemblare il motore è necessario smontare la flangia dal riduttore (vedere schema di montaggio 2 a pag. 17).

* To mount the motor it is necessary to remove the gearbox flange (see assembly drawing 2 on page 17).

* Vor dem Einbauen des Motors soll die Getriebeflangsch abmontiert werden (siehe Bauanleitung 2 auf Seite 17).

Schema di montaggio / Assembly drawing / Bauanleitung 1

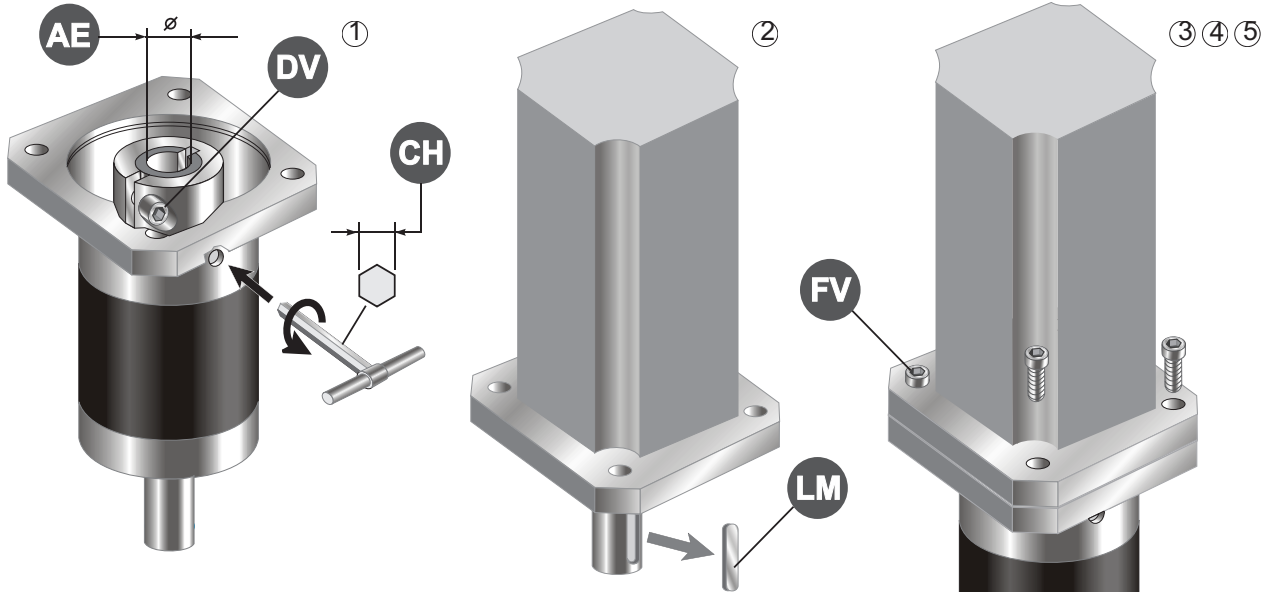

- 1 - Allentare la vite di serraggio del morsetto (DV)
- 2 - Estrarre la linguetta (LM) dall'albero motore
- 3 - Pulire le superfici di contatto delle flange motore e riduttore
- 4 - Calettare il motore sul riduttore evitando urti
- 5 - Stringere le viti di assemblaggio (FV) in modo alternato
- 6 - Serrare lavite (o le viti) del morsetto (DV) alla coppia (CS) indicata in tabella

- 1 - Unloose the fastening screw (or screws) of the clamp (DV)
- 2 - Remove the key (LM) from motor shaft
- 3 - Clean the contact surfaces of motor flange/gearbox flange
- 4 - Avoid impacts while fitting motor to gearbox
- 5 - Tighten the assembling screws (FV) alternatively
- 6 - Tighten the clamp screw, or screws (DV) according to the torque (CS) reported in the table

- 1 - die Befestigungsschraube der Klammer (DV) lockern
- 2 - die Feder (LM) aus Getriebe und Motorwelle ziehen
- 3 - die Motorflansch / Getriebeflansch Kontaktfläche reinigen
- 4 - Motor und Getriebe ohne Stöße verkeilen
- 5 - die Befestigungsschrauben (FV) abwechselnd anziehen
- 6 - die Schraube (oder Schrauben) der Klammer (DV) zu dem in der Tabelle angegebenen Anzugsmoment anziehen

EP 55	AE	6	6.35	7	8	9	9.52	11					
	DV	M4											
	NV	1											
	CH	3											
	CS [Nm]	4.8											
EP 75	AE	6	6.35	7	8	9	9.52	11	12	12.7	14		
	DV	M4											
	NV	1											
	CH	3											
	CS [Nm]	4.8											
EP 90	AE	9	9.52	11	12	12.7	14	15.87	16	19			
	DV	M4								M5			
	NV	1								1			
	CH	3								4			
	CS [Nm]	4.8								9.4			
EP 120	AE	12.7	14	15.87	16	19	22	24	28				
	DV	M4			M5				M6				
	NV	1			1				2				
	CH	3			4				5				
	CS [Nm]	4.8			9.4				16.2				
EP 155	AE	15.87	16	19	22	24	28	32	35	38			
	DV	M6			M6				M6				
	NV	1			2				3				
	CH	5			5				5				
	CS [Nm]	16.2			16.2				16.2				

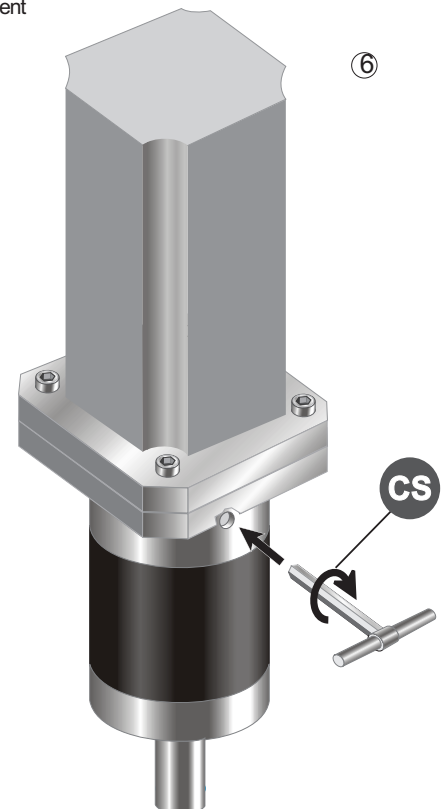

AE= Albero entrata / Input shaft / Antriebswelle
DV= Diametro vite / Screw diameter / Schraubendurchmesser

NV= Numero viti / Number of screw / Schraubenanzahl
CS= Coppia di serraggio / Setting torque / Spannungsmoment

1.7 Istruzioni per il montaggio del motore

1.7 Instructions for assembly of motor

1.7 Anleitung für Motormontage

Schema di montaggio / Assembly drawing / Bauanleitung 2

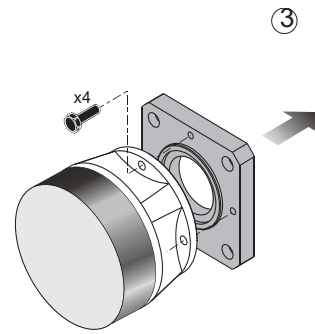
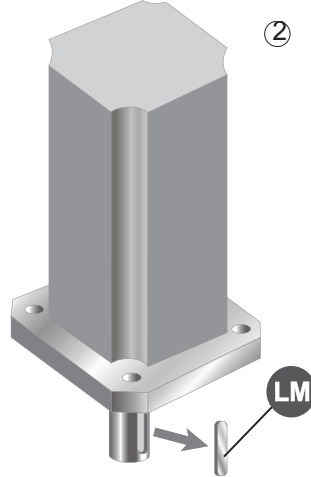
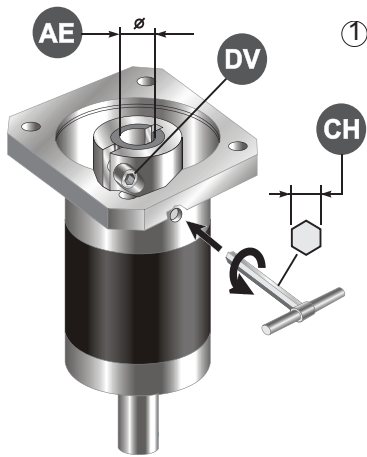

④ ⑤

- 1 - Allentare la vite di serraggio del morsetto (DV)
- 2 - Estrarre la linguetta (LM) dall'albero motore
- 3 - Smontare la flangia dal riduttore
- 4 - Pulire le superfici di contatto delle flange motore e riduttore
- 5 - Fissare la flangia sul motore
- 6 - Calettare il motore sul riduttore evitando urti
- 7 - Stringere le viti di assemblaggio (FV) in modo alternato
- 8 - Serrare la vite (o le viti) del morsetto (DV) alla coppia (CS) indicata in tabella

- 1 - Unloose the fastening screw (or screws) of the clamp (DV)
- 2 - Remove the key (LM) from motor shaft
- 3 - Remove the flange from the gearbox
- 4 - Clean the contact surfaces of motor flange/gearbox flange
- 5 - Fix the flange on the motor
- 6 - Avoid impacts while fitting motor to gearbox
- 7 - Tighten the assembling screws (FV) alternately
- 8 - Tighten the clamp screw, or screws (DV) according to the torque (CS) reported in the table

- 1 - die Befestigungsschraube der Klammer (DV) lockern
- 2 - die Feder (LM) aus Getriebe und Motorwelle ziehen
- 3 - die Flansch von Getriebe abmontieren
- 4 - die Motorflansch / Getriebe-flansch Kontaktfläche reinigen
- 5 - die Flansch an Motor befestigen
- 6 - Motor und Getriebe ohne Stöße verkeilen
- 7 - die Befestigungsschrauben (FV) abwechselnd anziehen
- 8 - die Schraube (oder Schrauben) der Klammer (DV) zu dem in der Tabelle angegebenen Anzugsmoment anziehen

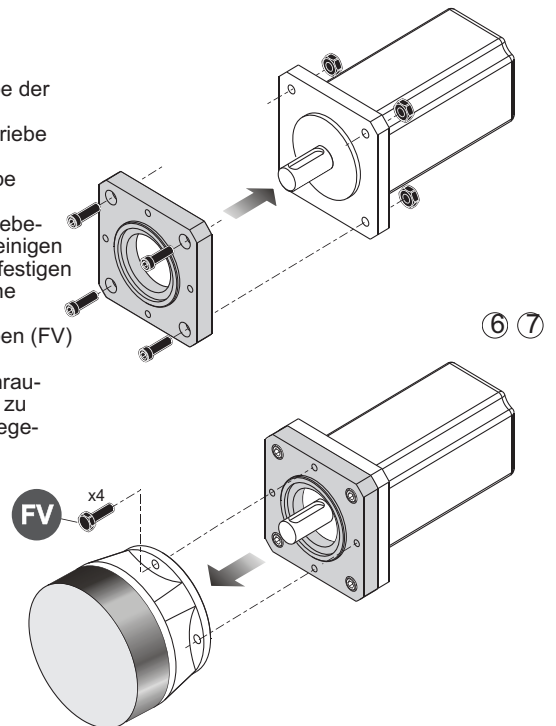

⑥ ⑦

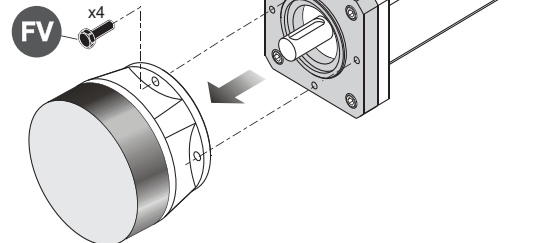

⑧

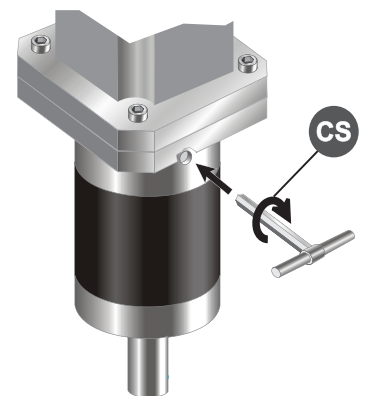

EP 55	AE	6	6.35	7	8	9	9.52	11				
	DV								M4			
	NV								1			
	CH								3			
	CS [Nm]								4.8			
EP 75	AE	6	6.35	7	8	9	9.52	11	12	12.7	14	
	DV											M4
	NV											1
	CH											3
	CS [Nm]											4.8
EP 90	AE	9	9.52	11	12	12.7	14	15.87	16	19		
	DV											M4
	NV											1
	CH											3
	CS [Nm]											4.8
EP 120	AE	12.7	14	15.87	16	19	22	24	24	28		
	DV		M4									M5
	NV		1									1
	CH		3									4
	CS [Nm]		4.8									9.4
EP 155	AE	15.87	16	19	22	24	28	32	35	38		
	DV		M6									M6
	NV		1									2
	CH		5									5
	CS [Nm]		16.2									16.2

AE= Albero entrata / Input shaft / Antriebswelle
 DV= Diametro vite / Screw diameter / Schraubendurchmesser

NV= Numero viti / Number of screw / Schraubenanzahl
 CS= Coppia di serraggio / Setting torque / Spannungsmoment